



REGULATIONS 
All Equipment is CE marked

Medical devices
Directive 93/42/CEE (Medical Devices Directive) and D. Lgs 24
Febbraio 1997, n. 46 - medical device Class I (rule 12)
annexe IX dir. 93/42/CEE

NORME 
Tutte le attrezzature sono a marchio CE

Dispositivi medici
Direttiva 93/42/CEE concernente i dispositivi medici e D. Lgs 24
Febbraio 1997, n.46 - dispositivo medico di classe I (regola 12)
secondo l'allegato IX dir.93/42/CEE

GYNAECOLOGY
GINECOLOGIA



* M: Nefos 6 Standard version with thigh support pair / Versione standard con coppia di reggicose Stool 010/S



Version with manual legrest / Versione con gamba manuale



Seat hole with a practical stainless steel bowl / Seduta con foro e pratica vaschetta inox

COD. 1159

Lemi Gyno is equipped with high-performance and silent electronics and a practical standard foot pedal control. Upon request, the version with manual legrest allows the chair to become a functional examination bed. Anatomic mattress with wide customization.

IDEAL FOR: diagnostics, gynecological, ultrasound and colposcopic examinations

Lemi Gyno è dotata di elettronica altamente performante e silenziosa e di una pratica pedaliera standard. Su richiesta, la versione con gamba manuale consente alla poltrona di diventare un lettino funzionale. Materasso anatomico con ampia possibilità di personalizzazione.

IDEALE PER: esami diagnostici, ginecologici, ecografici e colposcopici.

* The images are for illustrative purposes only and may not reflect the actual image of the finishing.

* Le immagini hanno valore puramente illustrativo e possono non rispecchiare l'immagine reale della finitura.

Focus on

- Standard foot pedal control with 2 MEMORY functions
- END function: automatic return to flat position (flat and minimum height) **NEW**
- AUT function: automatic return to the original position (chair)
- Fire retardant class 1IM, "Azo" free, antibacterial, antifungal covering
- Entirely enclosed ABS casing
- Fully customizable
- Standard version includes: 3 electric motors (height, back, trendelenburg adjustment), foot pedal control and anatomic mattress, stainless steel basin, thigh support pair, seat guides pair, fixed clamps pair, stainless steel handles and roll holder

- Pedaliera standard con 2 funzioni MEMORIE
- Funzione END: ritorno automatico alla posizione piatta (piatto e altezza minima) **NEW**
- Funzione AUT: ritorno automatico alla posizione base (poltrona)
- Rivestimento ignifugo classe 1IM, "Azo" free, antibatterico, antimicotico
- Carter in ABS completamente chiuso
- Totalmente personalizzabile
- La versione standard include: 3 motori elettrici (regolazione altezza, schiena e trendelenburg), pedaliera e materasso anatomico, vaschetta in acciaio inossidabile, coppia di reggicose, coppia guide seduta, coppia morsetti fissi, maniglie in acciaio inossidabile e portarotolo

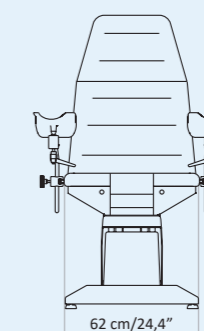
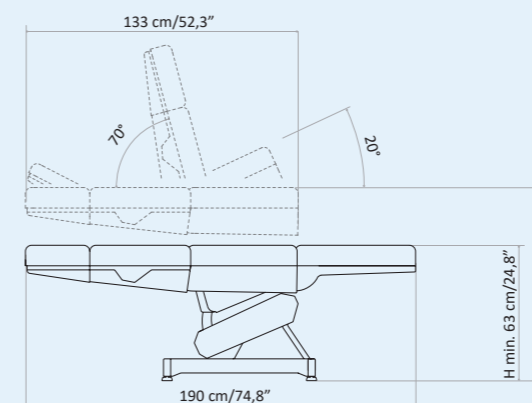

Packaging details

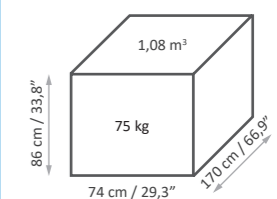

MAXIMUM CAPACITY PORTATA MASSIMA **200 kg**

STANDARD CONTROL

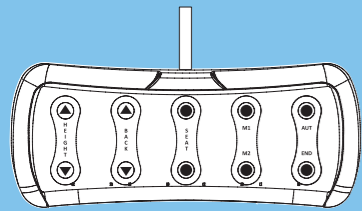

3M

3 ELECTRIC MOTORS

MEMORY

M1 - M2 MEMORY FUNCTION

AUT

AUT FUNCTION

END

END FUNCTION

COMANDO STANDARD

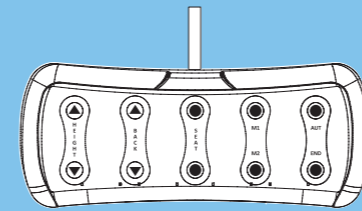

3M

3 MOTORI ELETTRICI

MEMORY

M1 - M2 FUNZIONI MEMORIE

AUT

FUNZIONE AUT

END

FUNZIONE END



63-90 cm
(24,8" - 35,6")

Seat hole with a practical stainless steel bowl
16,3 x 10,3 x 4,4h cm - 6,4" x 4" x 1,7" h

Seduta con foro e pratica vaschetta inox
16,3 x 10,3 x 4,4h cm - 6,4" x 4" x 1,7" h

Electric height
Altezza elettrica



20°

Electric Trendelenburg
Trendelenburg elettrico



70°

Electric backrest
Schiena elettrica



Manual legrest available upon request to get the bed position
Gamba manuale a richiesta per ottenere la posizione lettino



MATTRESS CUSTOMIZATION PERSONALIZZAZIONE MATERASSO

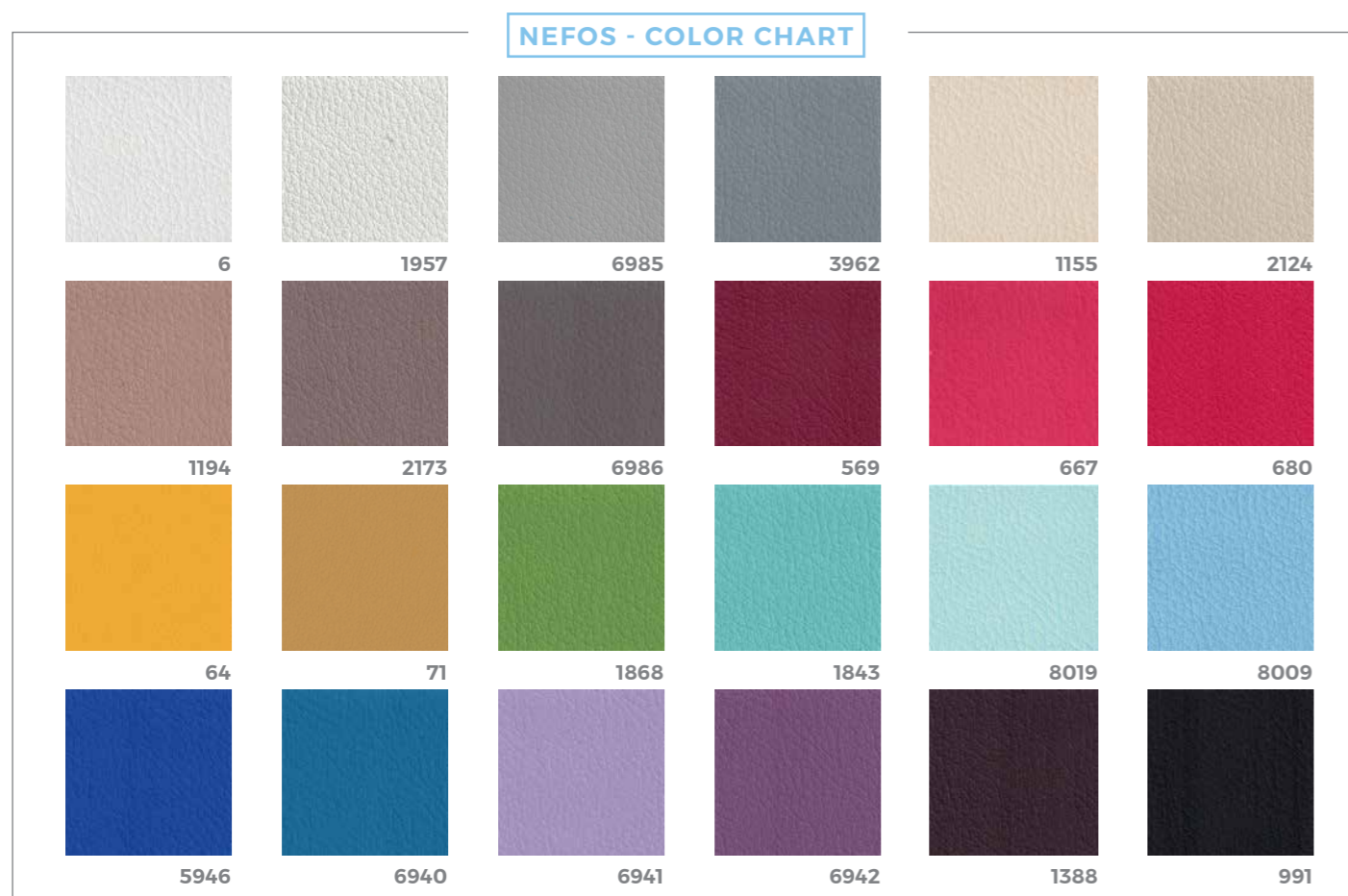

The innovative Nefos materials - which are exclusive for LEMI products - and their special finishing touch guarantee easy-cleaning and hygiene. Their extraordinary structural qualities will persist through the years. An incredibly elastic texture enhances the mattress softness and quality at its best.

Gli innovativi materiali Nefos - che sono un'esclusiva dei prodotti LEMI - ed il loro speciale tocco di finitura garantiscono una facile pulizia e igiene. Le loro straordinarie qualità strutturali permangono nel corso degli anni. Una texture incredibilmente elastica migliora al massimo la morbidezza e la qualità del materasso.

The images are for illustrative purposes only and may not reflect the actual finish of the product, particularly when viewed through a screen. Therefore, the **SELECTION OF MATTRESS FABRICS** must take place **AFTER CONSULTING** the **PHYSICAL SAMPLES** of the **COLOR CHARTS**.

ANTIMICROBIAL TECHNOLOGY TECNOLOGIA ANTIMICROBICA

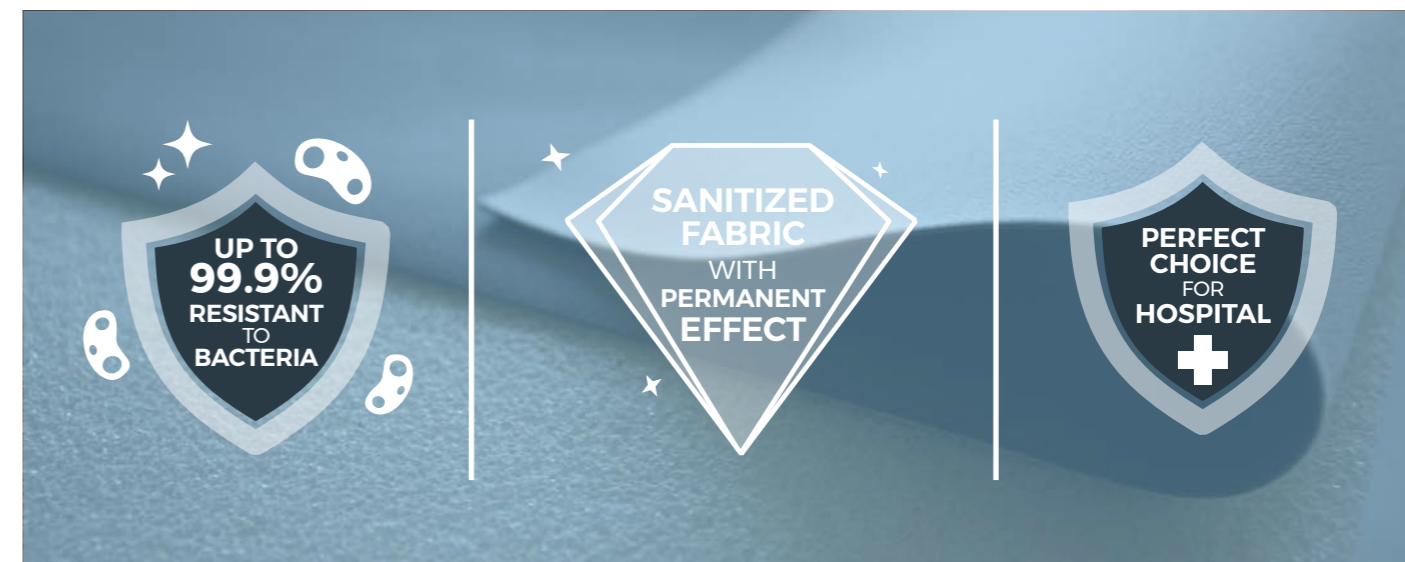

WHAT DOES IT MEAN?

The Nefos vinyl leather fabric is made through production processes involving an antimicrobial additive technology. Studies show that fabrics treated with this technology are up to 99.9% resistant to harmful bacteria.

The exceptional result that derives from it is a sanitized fabric with a permanent effect, whose matrix guarantees safety from any contamination thanks to the antibacterial, antifungal and anti-mold effect, which protects the coating from fungal attacks that can cause damage or bad smells, for the entire product's life cycle. The antimicrobial additive technology protects the fibers without changing their characteristics, thus preserving their freshness over time.

A high level of hygiene is essential, that's why this kind of technology was chosen by LEMI for all its bed and chair lines. The peculiarity of these coatings has allowed LEMI to give further value to its products, since thanks to this technology, the cleaning phase of Nefos vinyl leather fabric does not require the use of sanitizing products but requires the use of a soft cloth moistened and soapy, to be rinsed simply with clean water.

CHE COSA SIGNIFICA?

La linea di rivestimenti in vinilpelle Nefos è realizzata attraverso processi produttivi che coinvolgono una tecnologia additivante antimicrobica. Studi dimostrano che i tessuti trattati con questa tecnologia sono resistenti fino al 99,9% ai batteri nocivi.

Il risultato eccezionale che ne deriva è un tessuto igienizzato ad effetto permanente, la cui matrice garantisce sicurezza da eventuali contaminazioni grazie all'effetto antibatterico, antifungino e antimuffa, il quale protegge il rivestimento da attacchi micotici che possono essere causa di danni o di cattivi odori, per l'intera durata del ciclo di vita del prodotto. La tecnologia additivante antimicrobica protegge le fibre senza modificarne le caratteristiche, conservandone così la freschezza nel tempo.

Un alto livello di igiene è fondamentale, ecco perché questo tipo di tecnologia è stata scelta da LEMI per tutte le sue linee di poltrone e lettini. La peculiarità di questi rivestimenti ha permesso a LEMI di dare un ulteriore pregio ai propri prodotti, poiché proprio grazie a questa tecnologia, la fase di pulizia dei tessuti vinilpelle Nefos non necessita dell'utilizzo di prodotti igienizzanti ma prevede l'uso di un panno morbido inumidito e insaponato, da sciacquare semplicemente con acqua pulita.

Le immagini hanno valore puramente illustrativo e possono non rispecchiare la finitura reale del prodotto, in particolare se visualizzate attraverso uno schermo. Pertanto la **SELEZIONE** dei **RIVESTIMENTI DEI MATERASSI** deve avvenire **PREVIA CONSULTAZIONE** della **CAMPIONATURA FISICA** delle **CARTELLE COLORI**.

BASE CUSTOMIZATION PERSONALIZZAZIONE BASE

ABS PLASTIC FINISHES



White
Bianco



Grey
Grigio



Black
Nero

We provide a thermoformed ABS base, completely closed to prevent any infiltration of powders or liquids. The result is a very strong material that is scratch resistant and easy to clean.

Forniamo una base in ABS termoformato, completamente chiuso per evitare qualsiasi infiltrazione di polveri o liquidi. Il risultato è un materiale molto robusto, resistente ai graffi e facile da pulire.

ACCESSORIES UPON REQUEST ACCESSORI SU RICHIESTA

All chairs have a standard setting customizable upon request.

Tutte le poltrone hanno una configurazione standard personalizzabile su richiesta.



Wireless foot pedal control with memory function
(NO foot pedal with cable NO remote control)
Pedaliera wireless con funzione memorie
(NON compatibile con il pedale a filo e con la pulsantiera)



Handset control with memory function
Pulsantiera con funzione memorie

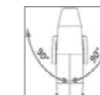

Option 180° rotation
Opzione rotazione 180°



I.V. Rod
(fixed with rotating clamp and guides on the back)
Asta portaflebo
(da fissare con morsetto girevole e guide schiena)



Fixed clamp
Morsetto fisso



Rotating clamp
Morsetto girevole



Medical armrest couple
(to be fixed with rotating clamp and guides on the back)
Coppia braccioli medicali
(da fissare con morsetti girevoli e guide schiena)



Curtain holder
(fixed with rotating clamp and guides on the seat)
Reggitelo
(da fissare con morsetto girevole e guide schiena)



Leg support
Supporto gamba



Back guide couple
Coppia guide schiena



Colposcope support
Supporto colposcopio



Heel support couple
(fixed with fix clamp and guides on the seat)
Coppia reggitallone
(da fissare con morsetti fissi e guide sulla seduta)



Wheels with brake
Ruote con freno



GYNO Lamp with stand
Lampada GYNO con stativo



Inox tray with support
(fixed with fix clamp and guides on the seat)
Vassoio inox completo di telaio
(da fissare con morsetto fisso e guide seduta)



UK cable
Cavo UK



USA cable
Cavo USA



Customization with logo
Personalizzazione con logo

LEMI MATTRESSES

The MATTRESSES of the LEMI MEDICAL line are made with the best quality materials to ensure maximum comfort for both the patient and the doctor.

Each mattress is HANDCRAFTED, therefore the ACTUAL MEASUREMENTS MAY VARY from those indicated in the catalogue by approximately ± 1 cm (also based on the selected configuration).

MATERASSI LEMI

I MATERASSI della linea MEDICALE LEMI sono realizzati con materiali della migliore qualità per garantire il massimo comfort sia per il paziente che per il medico.

Ogni materasso è realizzato A MANO, pertanto le MISURE REALI POTREBBERO VARIARE rispetto a quelle indicate nel catalogo di circa ± 1 cm (anche in base alla configurazione selezionata).



GYNO PLUS

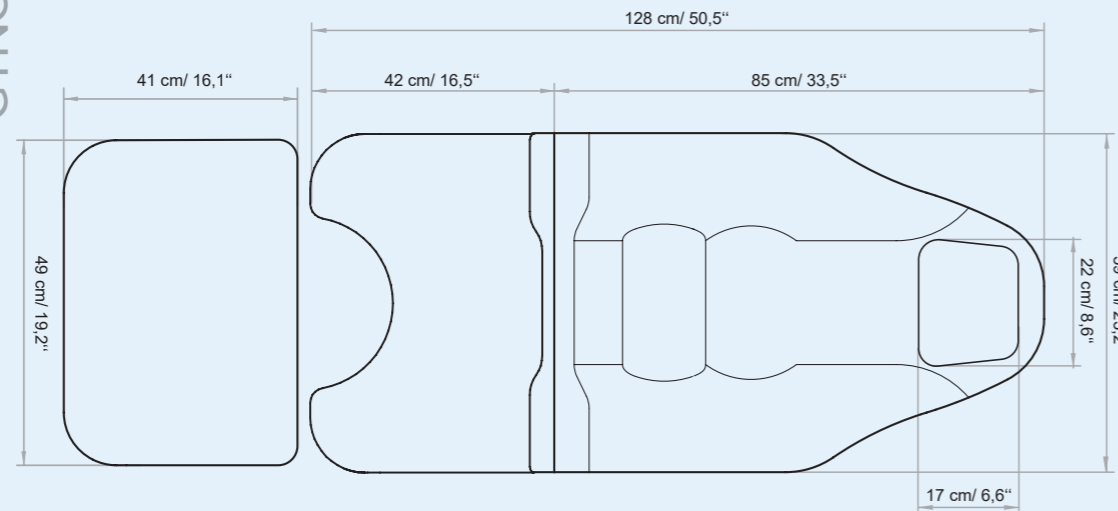

GYNO

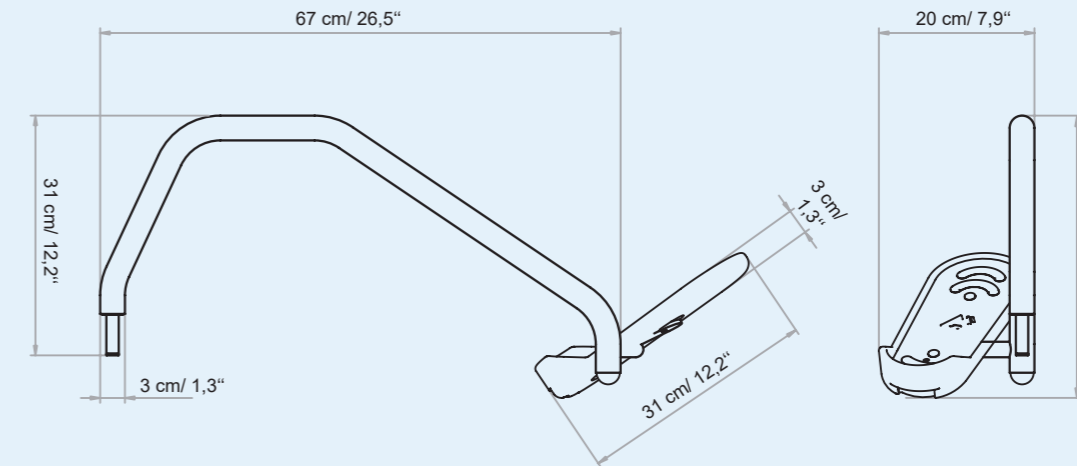
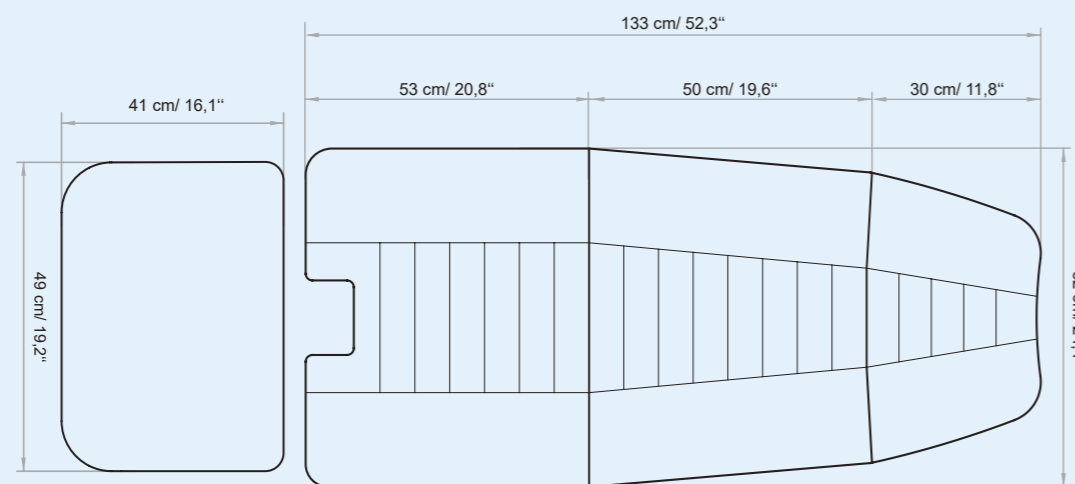

FOOT SUPPORT

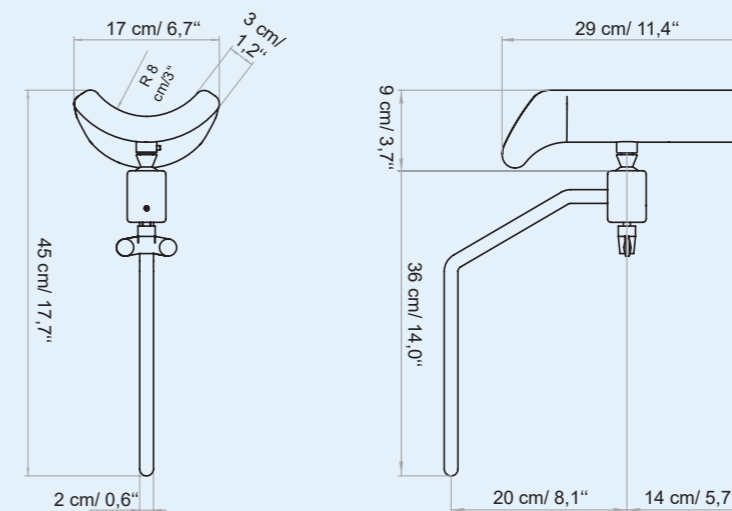

THIGH SUPPORT

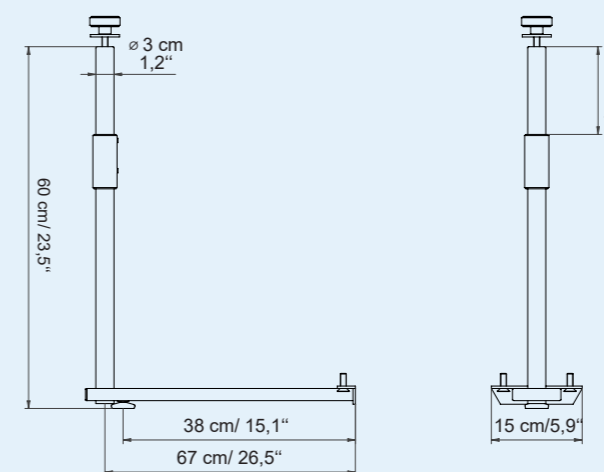

COLPOSCOPE SUPPORT



TECHNICAL REQUIREMENTS

CARATTERISTICHE TECNICHE

ABSORPTION ASSORBIMENTO	VOLTAGE VOLTAGGIO	POWER POTENZA	FREQUENCY FREQUENZA	PROTECTION RATING GRADO DI PROTEZIONE	ELECTRIC SYSTEM CONFORMS TO CEI NORMS IMPIANTO ELETTRICO A NORME CEI	CONTROL BOX CENTRALINA
4 Amax (1,7 A)	100 Vac (240Vac)	250W	50/60 Hz	IP 54	60601-1	CLASS II

TECHNICAL SPECIFICATION / SPECIFICHE TECNICHE

MINIMUM HEIGHT: 63 CM / 24,8"

MAXIMUM HEIGHT: 90 CM / 35,6"

ANGLE OF INCLINATION TRENDELENBURG: 20°

ANGLE OF INCLINATION BACKREST: 70°

MATTRESS LENGTH: 133 CM / 52,3"

MATTRESS LENGTH WITH LEGREST: 190 CM / 74,8"

MATTRESS WIDTH: 62 CM / 24,4"

ROTATION: 180°

LATEX-FREE, NON-TOXIC AND NON-CARCINOGENIC MATERIALS

FIRE-RESISTANT UPHOLSTERY: UNI 9175 CLASS I M

ALTEZZA MINIMA: 63 CM

ALTEZZA MASSIMA: 90 CM

ANGOLO INCLINAZIONE TRENDELENBURG: 20°

ANGOLO INCLINAZIONE SCHIENA: 70°

LUNGHEZZA MATERASSO: 133 CM

LUNGHEZZA MATERASSO GAMBE ESTESE: 190 CM

LARGHEZZA MATERASSO: 62 CM

ROTAZIONE: 180°

MATERIALI PRIVI DI LATTICE, ATOSSICI E NON CANCEROGENI

RIVESTIMENTO IGNIFUGO: UNI 9175 CLASS I M

WARRANTY / GARANZIA

STRUCTURE: 10 YEARS

MOTORS AND CONTROL: 2 YEARS

UNDEFORMABLE FOAM: 5 YEARS

STRUTTURA: 10 ANNI

MOTORI E CONTROLLI: 2 ANNI

GOMMA INDEFORMABILE: 5 ANNI

REGULATIONS

All Equipment is **CE** marked

Electrical equipment and beds

Directive 2006/42/CE (Machinery Directive) and national regulations.
Directive 2014/30/UE (Electromagnetic Compatibility Directive) and national regulations.
MDR Regulation 745/2017 (EU). Class I Medical Device.

Hydraulic equipment and beds

Directive 2006/42/CE (Machinery Directive) and national regulations.
MDR Regulation 745/2017 (EU). Class I Medical Device.

Images

The images are for illustrative purposes only and may not reflect the actual image of the product.

NORME

Tutte le attrezzature sono a marchio **CE**

Attrezzature e lettini elettrici

Direttiva 2006/42/CE (Direttiva Macchine) e disposizioni nazionali di attuazione.
Direttiva 2014/30/UE (Direttiva Compatibilità elettromagnetica) e disposizioni nazionali di attuazione.
Regolamento MDR 745/2017 (UE). Dispositivo Medico di Classe I.

Attrezzature e lettini idraulici

Direttiva 2006/42/CE (Direttiva Macchine) e disposizioni nazionali di attuazione.
Regolamento MDR 745/2017 (UE). Dispositivo Medico di Classe I.

Immagini

Le immagini hanno valore puramente illustrativo e possono non rispecchiare l'immagine reale del prodotto.

LemiMD
ITALIAN MEDICAL EQUIPMENT

Brusaferrì & C srl

Via Mara Maretti Soldi, 13
26011 Casalbuttano (CREMONA) ITALY
Phone +39-0374-363069 Fax +39-0374-363071
info@lemigroup.it service@lemigroup.it

www.lemimd.com