



REGULATIONS   
All Equipment is CE marked

**Medical devices**  
Directive 93/42/CEE (Medical Devices Directive) and D. Lgs 24  
24th February 1997, n. 46 - medical device Class I (rule 12)  
annexe IX dir. 93/42/CEE

NORME   
Tutte le attrezzature sono a marchio CE

**Dispositivi medici**  
Direttiva 93/42/CEE concernente i dispositivi medici e D. Lgs 24  
Febbraio 1997, n.46 - dispositivo medico di classe I (regola 12)  
secondo l'allegato IX dir.93/42/CEE

ENT - OPHTHALMOLOGY  
DENTISTRY  
ORL - OFTALMOLOGIA  
ODONTOIATRIA

# DENTAMED MOVE



## COD. 1218

*Dentamed Move is equipped with high-performance and silent electronics and a practical standard foot pedal control. The shape of the backrest is designed to approach the patient face. The move base helps with cleaning and disinfection of medical environments and the base size is suitable also for small rooms.*

*IDEAL FOR: dental, diagnostics, ENT and ophthalmic examinations.*

Dentamed Move è dotata di elettronica altamente performante e silenziosa e di una pratica pedaliera standard. La forma dello schienale è studiata per avvicinarsi al volto del paziente. La base MOVE facilita la pulizia e disinfezione dell'ambiente medico e l'ingombro della base è idoneo anche per le stanze piccole.

IDEALE PER: visite dentali, diagnostiche, ORL e oftalmologiche.

*\* The images are for illustrative purposes only and may not reflect the actual image of the finishing.*

*\* Le immagini hanno valore puramente illustrativo e possono non rispecchiare l'immagine reale della finitura.*

\* M: Nefos 1868

Version with ophthalmology head and seat guides / Versione con testa oftalmologica e guide seduta

## Focus on

Standard foot pedal control with 1 MEMORY function **NEW**

AUT function: automatic return to the original position (chair)

SYNCHRO function: synchronized backrest/legrest movement (ONLY by handset control)

Fire retardant class 11M, "Azo" free, antibacterial, antifungal covering

Standard version includes: 4 electric motors (height, back, leg, trendelenburg adjustment), foot pedal control, "Easy-to-clean" seamless anatomic mattress with Zak headrest, MOVE base with integrated wheels, back guides

Pedaliera standard con 1 funzione MEMORIE **NEW**

Funzione AUT: ritorno automatico alla posizione base (poltrona)

Funzione SYNCHRO: movimento schiena/gambe sincronizzato (SOLO con pulsantiera)

Rivestimento ignifugo classe 11M, "Azo" free, antibatterico, antimicotico

La versione standard include: 4 motori elettrici (regolazione altezza, schienale, gamba, trendelenburg), pedaliera, materasso anatomico senza cuciture "easy-to-clean" con testa Zak, base MOVE con ruote integrate, guide schiena

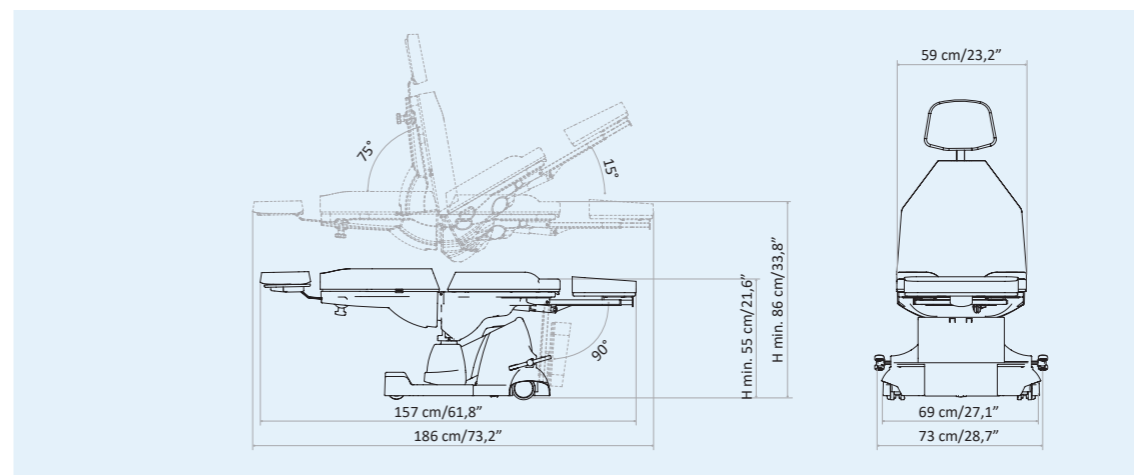

## Packaging details

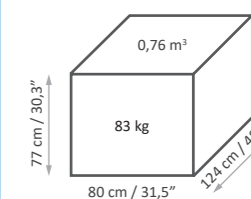

MAXIMUM CAPACITY  
PORTATA MASSIMA  
**200 kg**

# STANDARD CONTROL

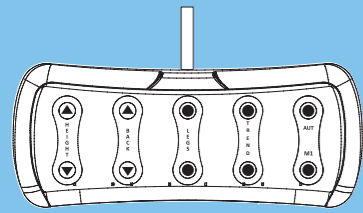

**4M**

4 ELECTRIC MOTORS

**MEMORY**

M1 - MEMORY FUNCTION

**AUT**

AUT FUNCTION

# COMANDO STANDARD

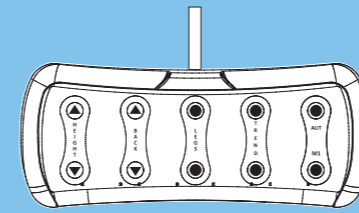

**4M**

4 MOTORI ELETTRICI

**MEMORY**

M1 - FUNZIONE MEMORIE

**AUT**

FUNZIONE AUT



Easy-to-clean anatomic mattress without stitching

Materasso anatomico senza cuciture per una facile igienizzazione

**55-86 cm**  
**(21,6"-33,8")**



Electric height  
Altezza elettrica



MOVE base with integrated wheels  
Base MOVE con ruote integrate

Front wheels: Ø100 cm with brake  
Rear wheels: Ø80 cm without brake  
Ruote anteriori: Ø100 cm con freno  
Ruote posteriori: Ø80 cm senza freno

**75°**

Electric backrest  
Schiena elettrica



**15°**

Electric Trendelenburg  
Trendelenburg elettrico



Version with ophthalmology head and seat guides  
Versione con testa oftalmologica e guide seduta

Electric legrest  
Gambe elettriche

**90°**



90° leg inclination  
Inclinazione gambe a 90°



# MATTRESS CUSTOMIZATION PERSONALIZZAZIONE MATERASSO

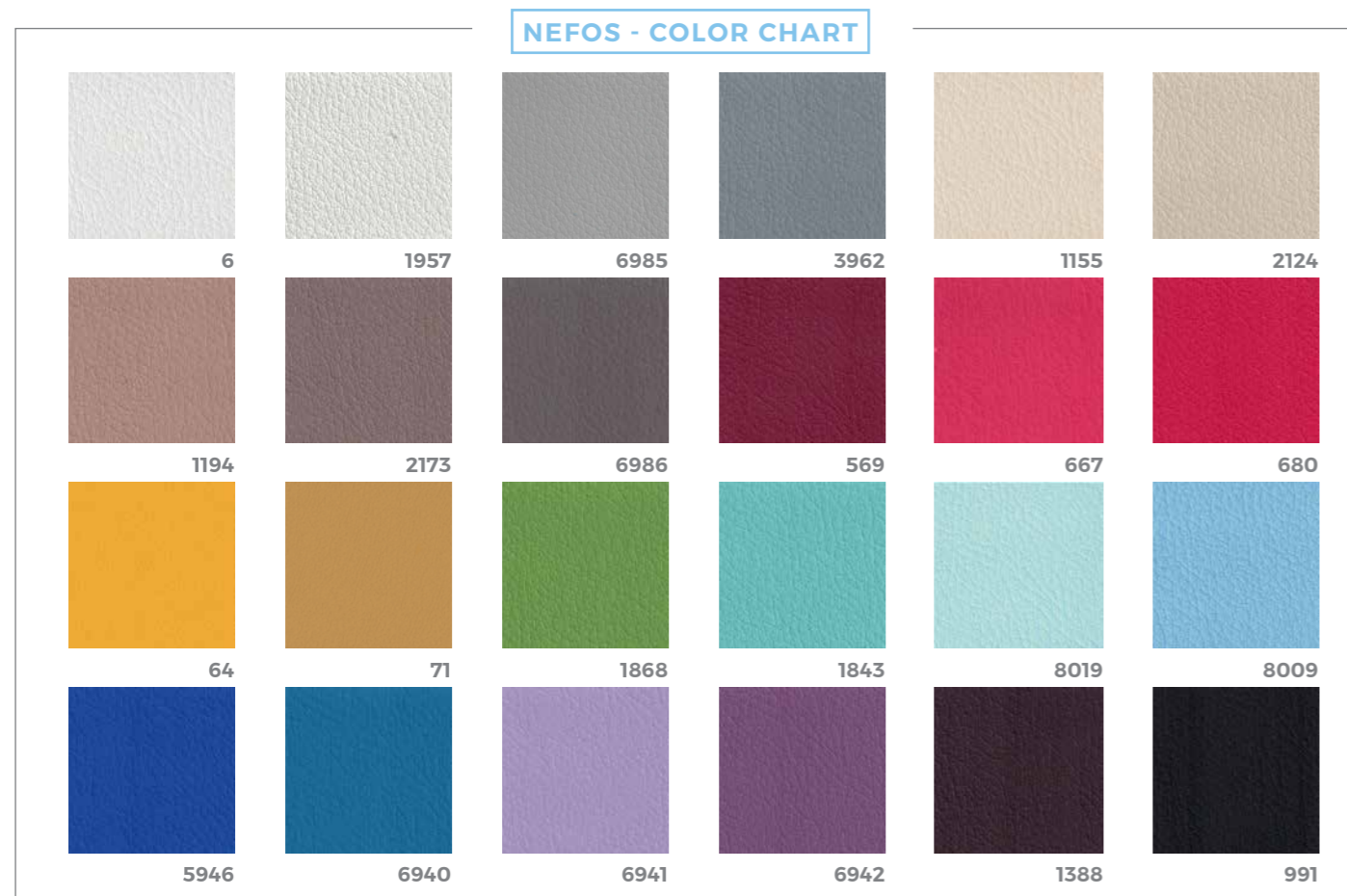

The innovative Nefos materials - which are exclusive for LEMI products - and their special finishing touch guarantee easy-cleaning and hygiene. Their extraordinary structural qualities will persist through the years. An incredibly elastic texture enhances the mattress softness and quality at its best.

Gli innovativi materiali Nefos - che sono un'esclusiva dei prodotti LEMI - ed il loro speciale tocco di finitura garantiscono una facile pulizia e igiene. Le loro straordinarie qualità strutturali permangono nel corso degli anni. Una texture incredibilmente elastica migliora al massimo la morbidezza e la qualità del materasso.

The images are for illustrative purposes only and may not reflect the actual finish of the product, particularly when viewed through a screen. Therefore, the **SELECTION OF MATTRESS FABRICS** must take place **AFTER CONSULTING** the **PHYSICAL SAMPLES** of the **COLOR CHARTS**.

# ANTIMICROBIAL TECHNOLOGY TECNOLOGIA ANTIMICROBICA



## WHAT DOES IT MEAN?

*The Nefos vinyl leather fabric is made through production processes involving an antimicrobial additive technology. Studies show that fabrics treated with this technology are up to 99.9% resistant to harmful bacteria.*

*The exceptional result that derives from it is a sanitized fabric with a permanent effect, whose matrix guarantees safety from any contamination thanks to the antibacterial, antifungal and anti-mold effect, which protects the coating from fungal attacks that can cause damage or bad smells, for the entire product's life cycle. The antimicrobial additive technology protects the fibers without changing their characteristics, thus preserving their freshness over time.*

*A high level of hygiene is essential, that's why this kind of technology was chosen by LEMI for all its bed and chair lines. The peculiarity of these coatings has allowed LEMI to give further value to its products, since thanks to this technology, the cleaning phase of Nefos vinyl leather fabric does not require the use of sanitizing products but requires the use of a soft cloth moistened and soapy, to be rinsed simply with clean water.*

## CHE COSA SIGNIFICA?

La linea di rivestimenti in vinilpelle Nefos è realizzata attraverso processi produttivi che coinvolgono una tecnologia additivante antimicrobica. Studi dimostrano che i tessuti trattati con questa tecnologia sono resistenti fino al 99,9% ai batteri nocivi.

Il risultato eccezionale che ne deriva è un tessuto igienizzato ad effetto permanente, la cui matrice garantisce sicurezza da eventuali contaminazioni grazie all'effetto antibatterico, antifungino e antimuffa, il quale protegge il rivestimento da attacchi micotici che possono essere causa di danni o di cattivi odori, per l'intera durata del ciclo di vita del prodotto. La tecnologia additivante antimicrobica protegge le fibre senza modificarne le caratteristiche, conservandone così la freschezza nel tempo.

Un alto livello di igiene è fondamentale, ecco perché questo tipo di tecnologia è stata scelta da LEMI per tutte le sue linee di poltrone e lettini. La peculiarità di questi rivestimenti ha permesso a LEMI di dare un ulteriore pregio ai propri prodotti, poiché proprio grazie a questa tecnologia, la fase di pulizia dei tessuti vinilpelle Nefos non necessita dell'utilizzo di prodotti igienizzanti ma prevede l'uso di un panno morbido inumidito e insaponato, da sciacquare semplicemente con acqua pulita.

Le immagini hanno valore puramente illustrativo e possono non rispecchiare la finitura reale del prodotto, in particolare se visualizzate attraverso uno schermo. Pertanto la **SELEZIONE** dei **RIVESTIMENTI DEI MATERASSI** deve avvenire **PREVIA CONSULTAZIONE** della **CAMPIONATURA FISICA** delle **CARTELLE COLORI**.

# BASE CUSTOMIZATION PERSONALIZZAZIONE BASE

## ABS PLASTIC FINISHES



Grey  
Grigio

We provide a thermoformed ABS base, completely closed to prevent any infiltration of powders or liquids. The result is a very strong material that is scratch resistant and easy to clean.

Forniamo una base in ABS termoformato, completamente chiuso per evitare qualsiasi infiltrazione di polveri o liquidi. Il risultato è un materiale molto robusto, resistente ai graffi e facile da pulire.

# ACCESSORIES UPON REQUEST ACCESSORI SU RICHIESTA

All chairs have a standard setting customizable upon request.

Tutte le poltrone hanno una configurazione standard personalizzabile su richiesta.



Wireless foot pedal control with memory function  
(NO foot pedal with cable NO remote control)  
Pedaliera wireless con funzione memorie  
(NON compatibile con il pedale a filo e con la pulsantiera)



Handset control with memory function  
Pulsantiera con funzione memorie



I.V. Rod  
(fixed with rotating clamp and guides on the back)  
Asta portaflebo  
(da fissare con morsetto girevole e guide schiena)



Seat guide couple  
Coppia guide seduta



Fixed clamp  
Morsetto fisso



Rotating clamp  
Morsetto girevole



Anto headrest for hair transplant  
Testa Anto per trapianto capelli



Strip headrest  
Testa strip



Headrest  
Poggiatesta



Ophthalmological headrest  
Testa oftalmologica



Medical armrest couple  
(to be fixed with rotating clamp and guides on the back)  
Coppia braccioli medicali  
(da fissare con morsetti girevoli e guide schiena)



Blood sample taking armrest couple  
(fixed with fix clamp and guides on the seat)  
Coppia braccioli da prelievo con snodo  
(da fissare con morsetto fisso e guide seduta)



Heel support couple  
(fixed with fix clamp and guides on the seat)  
Coppia reggitallone  
(da fissare con morsetti fissi e guide sulla seduta)



Thigh supports couple  
(fixed with fix clamp and guides on the seat)  
Coppia reggicoscce con snodo  
(da fissare con morsetti fissi e guide seduta)



Curtain holder  
(fixed with rotating clamp and guides on the seat)  
Reggitelo  
(da fissare con morsetto girevole e guide schiena)



Roll Holder  
Portarotolo



Cushion between seat and leg  
Cuscino tra seduta e gamba



Plastic leg protection  
Proteggi gambe in plastica



Inox tray with support  
(fixed with fix clamp and guides on the seat)  
Vassoio inox completo di telaio  
(da fissare con morsetto fisso e guide seduta)



UK cable  
Cavo UK



USA cable  
Cavo USA



Customization with logo  
Personalizzazione con logo

# LEMI MATTRESSES

The **MATTRESSES** of the **LEMI MEDICAL** line are made with the best quality materials to ensure maximum comfort for both the patient and the doctor.

Each mattress is **HANDCRAFTED**, therefore the **ACTUAL MEASUREMENTS MAY VARY** from those indicated in the catalogue by approximately  $\pm 1$  cm (also based on the selected configuration).

# MATERASSI LEMI

I **MATERASSI** della linea **MEDICALE LEMI** sono realizzati con materiali della migliore qualità per garantire il massimo comfort sia per il paziente che per il medico.

Ogni materasso è realizzato **A MANO**, pertanto le **MISURE REALI POTREBBERO VARIARE** rispetto a quelle indicate nel catalogo di circa  $\pm 1$  cm (anche in base alla configurazione selezionata).



THICKNESS  
SPESSORE  
9 / 12cm  
3,5" / 4,7"

DENTAMED

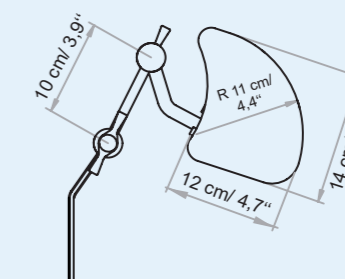
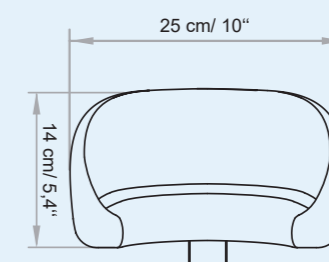
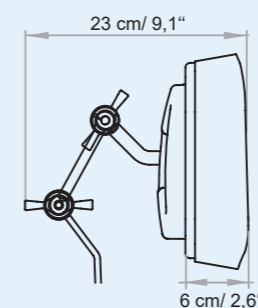
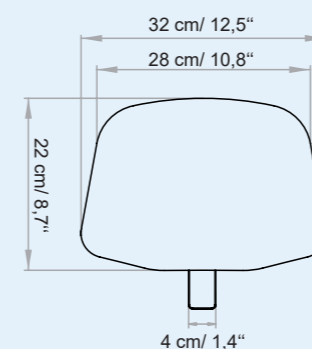
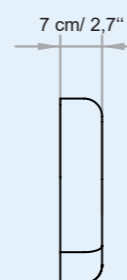
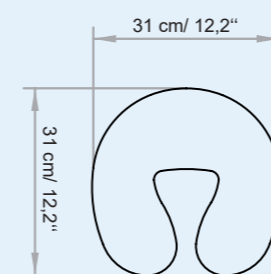
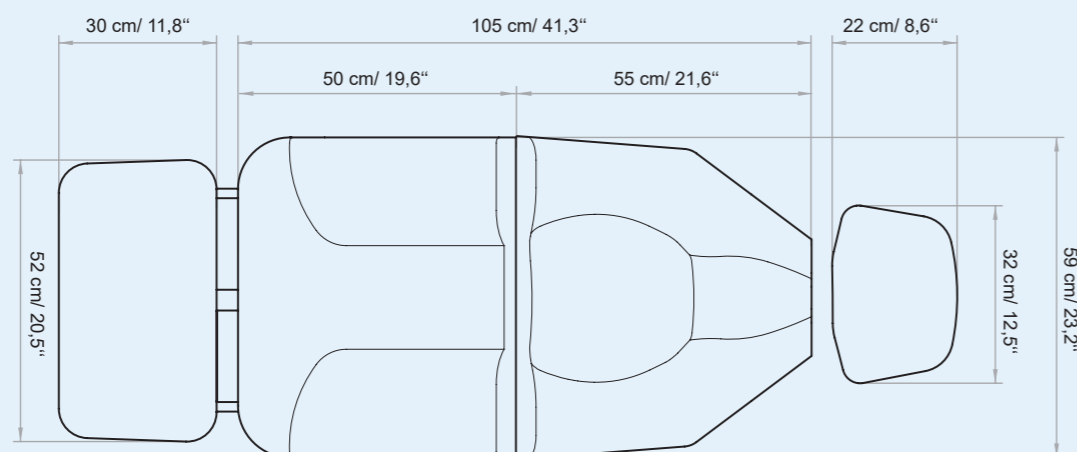

HEADS

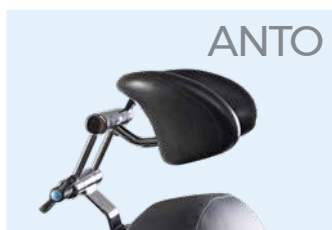
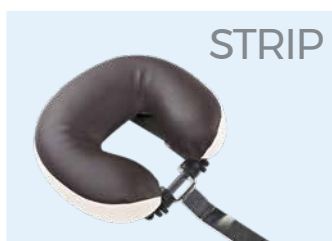

# TECHNICAL REQUIREMENTS

## CARATTERISTICHE TECNICHE

ABSORPTION ASSORBIMENTO	VOLTAGE VOLTAGGIO	POWER POTENZA	FREQUENCY FREQUENZA	PROTECTION RATING GRADO DI PROTEZIONE	ELECTRIC SYSTEM CONFORMS TO CEI NORMS IMPIANTO ELETTRICO A NORME CEI	CONTROL BOX CENTRALINA
4 Amax (1,7 A)	100 Vac (240Vac)	250W	50/60 Hz	IP 54	60601-1	CLASS II

### TECHNICAL SPECIFICATION / SPECIFICHE TECNICHE

MINIMUM HEIGHT: 55 CM / 21,6"

MAXIMUM HEIGHT : 86 CM / 33,8"

ANGOLO INCLINAZIONE TRENDELENBURG: 15°

ANGLE OF INCLINATION BACKREST: 75°

ANGLE OF INCLINATION LEG: 90°

MATTRESS LENGTH WITH LEGREST: 186 CM / 73,2"

MATTRESS WIDTH: 59 CM / 23,2"

LATEX-FREE, NON-TOXIC AND NON-CARCINOGENIC MATERIALS

FIRE-RESISTANT UPHOLSTERY : UNI 9175 CLASS I M

ALTEZZA MINIMA: 55 CM

ALTEZZA MASSIMA: 86 CM

ANGOLO INCLINAZIONE TRENDELENBURG: 15°

ANGOLO INCLINAZIONE SCHIENA: 75°

ANGOLO INCLINAZIONE GAMBE: 90°

LUNGHEZZA MATERASSO GAMBE ESTESE: 186 CM

LARGHEZZA MATERASSO: 59 CM

MATERIALI PRIVI DI LATTICE, ATOSSICI E NON CANCEROGENI

RIVESTIMENTO IGNIFUGO: UNI 9175 CLASS I M

### WARRANTY / GARANZIA

STRUCTURE: 10 YEARS

MOTORS AND CONTROL: 2 YEARS

UNDEFORMABLE FOAM: 5 YEARS

STRUTTURA: 10 ANNI

MOTORI E CONTROLLI: 2 ANNI

GOMMA INDEFORMABILE: 5 ANNI

#### REGULATIONS

All Equipment is **CE** marked

#### Electrical equipment and beds

Directive 2006/42/CE (Machinery Directive) and national regulations.  
Directive 2014/30/UE (Electromagnetic Compatibility Directive) and national regulations.  
MDR Regulation 745/2017 (EU). Class I Medical Device.

#### Hydraulic equipment and beds

Directive 2006/42/CE (Machinery Directive) and national regulations.  
MDR Regulation 745/2017 (EU). Class I Medical Device.

#### Images

The images are for illustrative purposes only and may not reflect the actual image of the product.

#### NORME

Tutte le attrezzature sono a marchio **CE**

#### Attrezzature e lettini elettrici

Direttiva 2006/42/CE (Direttiva Macchine) e disposizioni nazionali di attuazione.  
Direttiva 2014/30/UE (Direttiva Compatibilità elettromagnetica) e disposizioni nazionali di attuazione.  
Regolamento MDR 745/2017 (UE). Dispositivo Medico di Classe I.

#### Attrezzature e lettini idraulici

Direttiva 2006/42/CE (Direttiva Macchine) e disposizioni nazionali di attuazione.  
Regolamento MDR 745/2017 (UE). Dispositivo Medico di Classe I.

#### Immagini

Le immagini hanno valore puramente illustrativo e possono non rispecchiare l'immagine reale del prodotto.

**LemiMD**  
ITALIAN MEDICAL EQUIPMENT

#### Brusaferrì & C srl

Via Mara Maretti Soldi, 13  
26011 Casalbuttano (CREMONA) ITALY  
Phone +39-0374-363069 Fax +39-0374-363071  
info@lemigroup.it service@lemigroup.it

www.lemimd.com